



“The Spanish alternative in Water Purification Systems”

Wasserlab, a firm with over 15 years experience, designs and manufactures water purification systems to satisfy the daily pure and ultrapure water requirements of laboratories and companies.

We are manufacturers, and therefore we are in a position to offer both standard equipment and user bespoke equipment.

Wasserlab offers the market's best quality/price ratio with its water purification systems, and also its Maintenance and Technical Assistance Service.

Our company philosophy focuses on providing our clients with the fastest and most efficient after sales service.

We offer various solutions to your laboratory or company needs:

- Type I Ultrapure Water (Reagent Grade)
- Type II Purified Water (Analytical Grade)
- Type III Water (Osmotised)



The products are designed for use in:

LABORATORIES
Desktop equipment

HOSPITALS
High production equipment

INDUSTRY
Bespoke facilities

Type I and II Water specifications according to ASTM (American Society for Testing and Materials)

Characteristics	Type I (Reagent Grade)Water	Type II (Analytical Grade) Water	Type III (Osmotised) Water	Type IV
Conductivity ($\mu\text{S/cm}$)	0,056	1,0	4	5
Resistivity ($\text{M}\Omega\cdot\text{cm}$)	18,2	1,0	0,25	0,2
Total Organic Carbon (ppb)	10	50	200	
Sodium (ppb)	1	5	10	50
Chloride (ppb)	1	5	10	50
Total Silica (ppb)	3	3		
Endotoxins (IU/ml.)	< 0,03	< 0,25	-	-

Bacterial content ufc/ml <1. Requires use of 0.2 microns final filter.

National Committee for Clinical Laboratory Standards (NCCLS)

Parameter	Type I (Reagent Grade) Water	Type II (Analytical Grade) Water	Type III (Osmotised) Water
Bacteria (CFU/ml)	< 10	< 1000	NA
pH	NA	NA	5,0-8,0
Resistivity ($\text{M}\Omega\cdot\text{cm}$ @ 25°C)	> 10*	> 1	> 0,1
Silica (mg/L)	1	5	10
Total Solids (mg/L)	1	5	10
Organic Carbon Total Oxidisable (mg/L)	3	3	

* Measurement in line

ECOMATIC

TYPE II WATER

“Water that is always recently produced, with a constant, controlled quality”

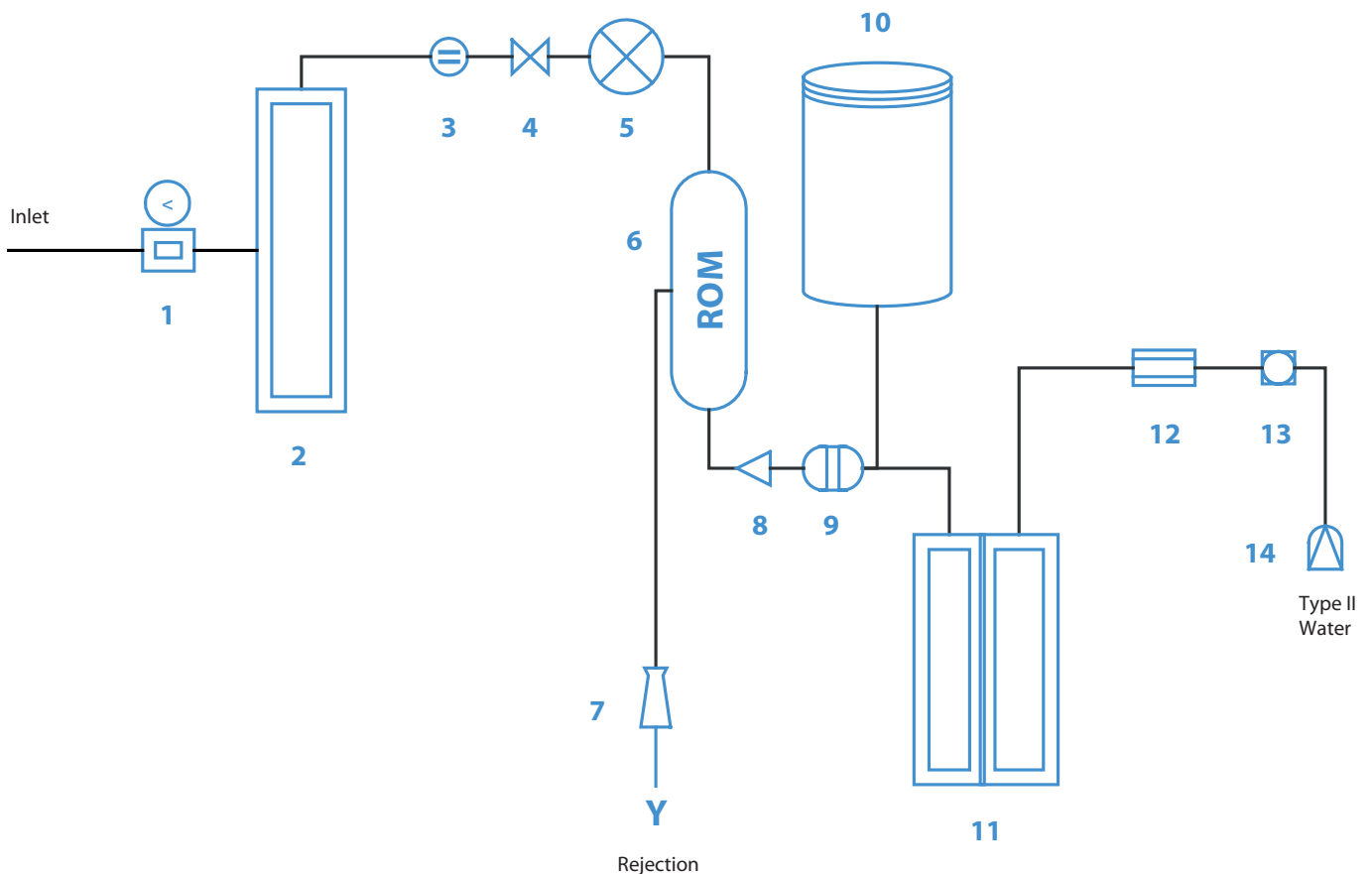

The Ecomatic Equipment always dispenses recently purified Type II water

- 1 Pressure regulator and manometer. 2 Pretreatment Module. 3 Pressure controller. 4 Electrovalve. 5 Pump. 6 Inverse osmosis module. 7 Flow rate regulator. 8 Check valve. 9 Pressure controller. 10 Pressurised osmotised water tank. 11 Deionisation module. 12 Conductivity cell. 13 Flow detector. 14 Dispensing tap.

Ecomatic: Compact water purification equipment that produces Type II (ASTM*, Analytical Grade) Water, using water directly from the mains

*American Society for Testing and Materials



Ecomatic provides Type II (Analytical Grade) Water, with productions ranging from 3 l/h to 10 l/h, according to model

The combination of water purification systems using inverse osmosis and deionisation, provides purified water with a constant quality, at a very competitive price.

The equipment **always dispenses recently produced Type II Water**, avoiding its deterioration through storage.

Continuous control of the purification process using a microprocessor

An easy-to-read digital screen informs users, at all times, of the following conditions:

- | The quality of the water produced measured in $\mu\text{S}/\text{cm}$, with a resolution of $\pm 0,1 \mu\text{S}/\text{cm}$.
- | The stage of the purification process (in production, full tank, equipment dispensing) and warnings, using easy-to-interpret symbols.

Applications

More than 90% of general laboratory assays require Type II Water:

- | Preparation of culture media
- | Preparing of reagents and buffer solutions
- | Cleaning the material
- | Clinical Analyses
- | Saline Mist Chambers and Climatic Test Chambers
- | Supplying equipment to produce Type I (Ultrapure) Water
- | Ecomatic can also provide Type III (Osmotised) Water for thermal disinfection apparatus and autoclaves.

Fully automatic operation for maximum peace of mind for users.

Warning set point parameters can be programmed as desired.

Easy to handle

Easy to install. Simple, quick maintenance, thanks to its system of exchangeable cartridges, using fast connections.



Type II Water Monitoring



AUTWOMATIC TYPE II WATER

“Always recently produced water, with controlled, monitored quality”

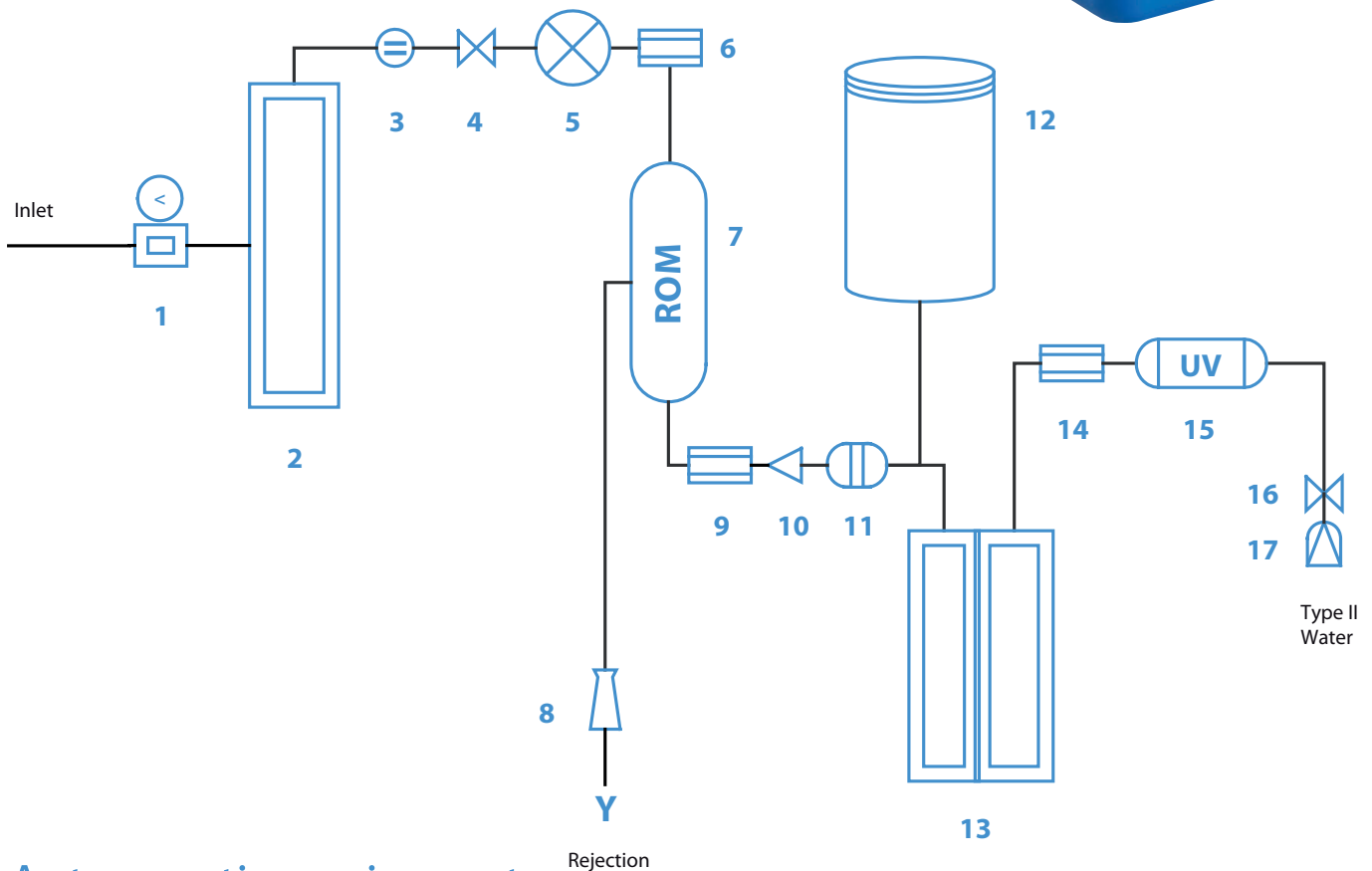

Autwomatic equipment:
Maximum peace of
mind for users

- 1 Pressure regulator and manometer. 2 Pretreatment module. 3 Pressure controller. 4 Electrovalve. 5 Pump. 6 Inlet water conductivity cell. 7 Inverse osmosis module. 8 Flow rate regulator. 9 Osmotised water conductivity cell. 10 Check valve. 11 Pressure controller. 12 Osmotised water pressurised tank. 13 Deionisation module. 14 Type II Water conductivity cell and temperature probe. 15 UV lamp. 16 Electrovalve. 17 Amicrobic final filter.



Pretreatment

This is the first purification step. The pretreatment module protects the inverse osmosis membrane by removing:

- | Particle (≥ 1 micra)
- | Chloride and colloids
- | Organic matter

It is sized according to the various model production flow rates Autwomatic.

Inverse osmosis

The high efficiency and performance inverse osmosis module provides a flow rate of 3/10 litres per hour (according to model) of osmotised water, removing:

- | 95-98% of dissolved inorganic salts.
- | >99% of dissolved organic matter (PM > 100 dalton).
- | >99.95% of microorganisms and particles.

Accumulation of osmotised water

The permeate water from the inverse osmosis module accumulates in a pressurised tank, which is opaque and airtight and protects the water from any contact with light and air, thereby preserving it from any possible contamination.

Monitoring

The Autwomatic microprocessor constantly monitors all the purification process parameters:

- | Real number of equipment operating hours.
- | Measurement in $\mu\text{S}/\text{cm}$ ($\pm 1 \mu\text{S}/\text{cm}$) of the conductivity of the equipment supply water.
- | Measurement in $\mu\text{S}/\text{cm}$ ($\pm 1 \mu\text{S}/\text{cm}$) of the conductivity of the permeate water from the inverse osmosis module.
- | % performance of the inverse osmosis module ($\pm 0.1\%$).

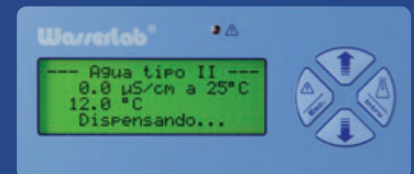
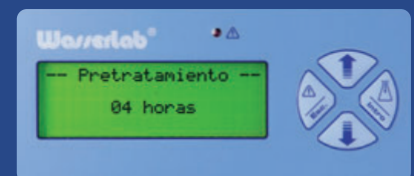

- | Measurement in $\mu\text{S}/\text{cm}$ of the conductivity of the Type II Water produced ($\pm 0,1 \mu\text{S}/\text{cm}$).
- | Water temperature. All the conductivity measurements are compensated at 25°C.
- | Equipment operating stage (Producing/ Full Tank/ Dispensing).

The software allows users to personalise the critical conductivity value of their water. The equipment will emit a visual and audible warning, notifying the need to replace the various consumables according to the values set.

Autwomatic: Automatic equipment with multi-parameter monitoring

Deionisation

A highly effective mixed bed of anion/cation ionic exchange resins removes any ions from the permeate water from the inverse osmosis module. The resulting water has a conductivity value $\leq 0.5 \mu\text{S}/\text{cm}$.



UV lamp

The disinfection equipment uses UV radiation to reduce the 5 logarithmic cycles bacterial content, providing a water with minimum bacterial contamination for those users who require these conditions.

For those laboratory applications where bacterial contamination is essential, a 0.2 micron amicrobic final filter ensures a bacterial count $\leq 1 \text{ ufc}/\text{ml}$.

Type II (Analytical Grade) Water

As shown in the flow diagram, the Wasserlab Autwomatic equipment stores the osmotised water, unlike other purification systems that store the Type II Water end product, with the subsequent loss of quality.

At the user's request, Autwomatic always dispenses maximum quality, recently purified Type II water.

Self-checking and preventive maintenance

The main advantage of the Autwomatic equipment is that users do not have to worry about regularly checking the equipment:

- | The Autwomatic software is configured to conduct a programmed self-check on system operation, constantly and effectively controlling the equipment components and the monitoring values of the quality of the water produced.

Users can program the following as desired:

- | Minimum performance of the inverse osmosis module.
- | Maximum conductivity of the Type II Water produced.

to anticipate any possible problems caused by using water of a non-desired quality.

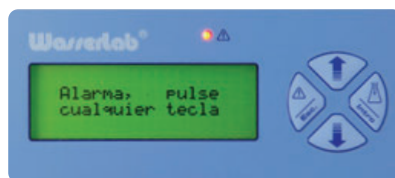
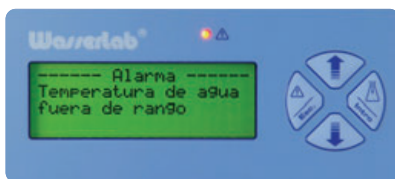
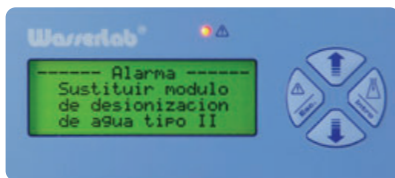

The microprocessor will provide preventive notification, in the form of an audible warning and message written on the screen, indicating the maintenance tasks required to guarantee the desired water quality.

- | Low performance of the inverse osmosis module.
- | Pretreatment Module Wear and Tear.
- | Deionisation Module Wear and Tear.
- | Temperature probe or conductivity probes not working properly.

Conductivity meter calibration and system check

The Autwomatic software allows adjusting and calibrating the conductivity meter using a certified standard based on the Deutscher Kalibrierdienst (DKD) German national standards.

The Wasserlab Technical Assistance Service offers, at the user's request:

1. Regular equipment calibration service.
2. Full system check over and corresponding certificate.

Applications

- | Research and analysis laboratories
- | Preparing microbiological culture media
- | Preparing buffer solutions
- | Cleaning the material
- | Autoclaves
- | Preparing reagents
- | Preparing semen doses
- | Green houses
- | Food and Drink Industries
- | Atomic Absorption
- | Hydroponic cultures
- | Chemical Industry
- | Pharmaceutical and Cosmetic Industry
- | Clinical Analysis
- | Veterinary Laboratories
- | Saline mist chambers
- | Climatic Test Chambers

ULTRAMATIC ULTRAPURE WATER

“The purification system of Ultrapure,
Type I (Reagent Grade) Water”

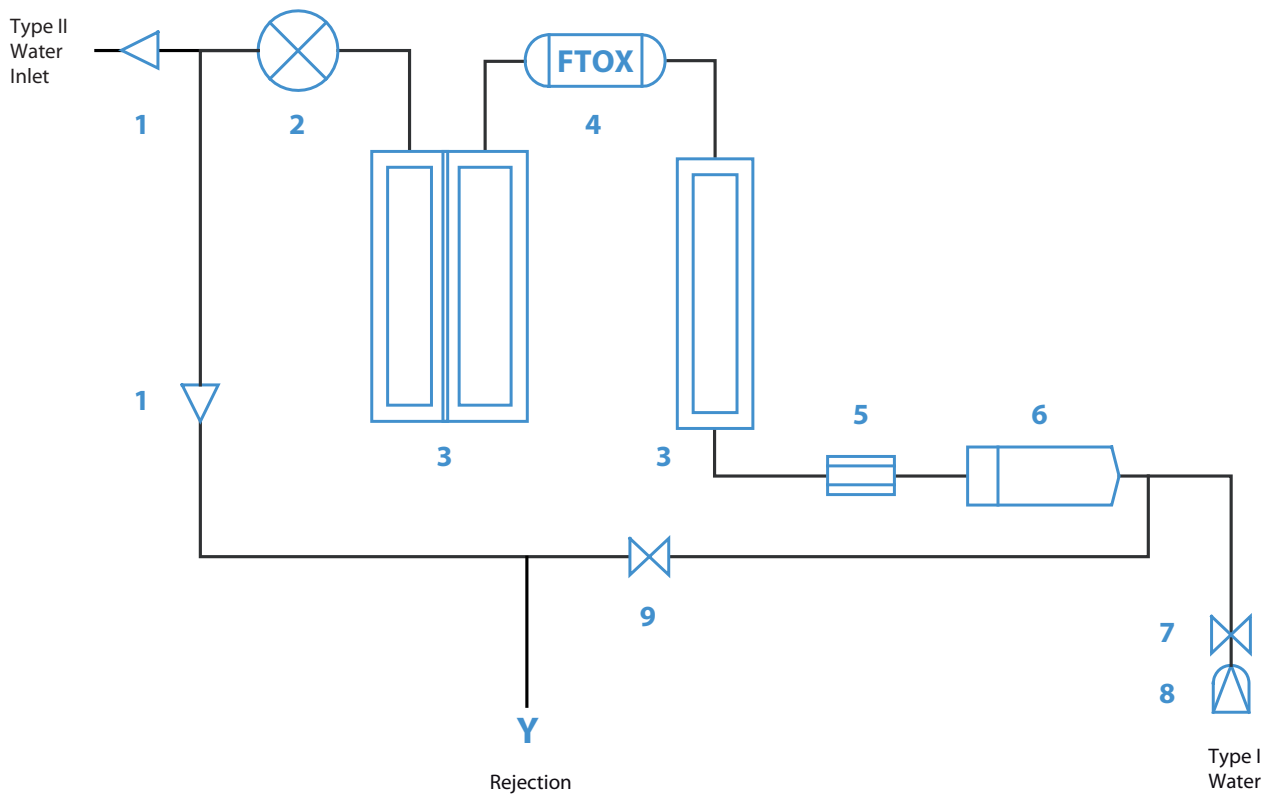

The Ultramatic equipment produces Type I
(Reagent Grade) Water according to the
ASTM Quality Standards

1 Check valve. 2 Pump. 3 GR. purification module. 4 Photo-oxidation lamp. 5 Resistivity cell and Temperature.
6 Ultra-filtering module. 7 Electrovalve. 8 Final filter. 9 Recirculation electrovalve.

Thanks to modern laboratory techniques it is possible to detect substances in increasingly lower concentrations, and this makes the purity requirements of the reagents used, increasingly more demanding.



Purified water, which is the main component in the solutions used in laboratories, is also subject to these purity requirements.

The quality of Type II Analytical Grade water is insufficient in this type of applications, and therefore it is necessary to use Ultrapure (Type I) Water. The ASTM standard defines Type I Reagent Grade Water for application in more sensitive techniques (*Table 1*).

The high capacity of Ultrapure water as a solvent allows it to extract contaminants from the air and from any other material with which it has been in contact.

As can be seen in the table attached, Ultrapure water is capable of "dissolving" ions such as Zinc, Lead, Copper, Iron or Aluminium from Pyrex glass (*Table 2*).

The Ultramatic equipment provides recently produced Ultrapure water.

Table 1

Conductivity ($\mu\text{S/cm}$)	0,056
Resistivity ($\text{M}\Omega\cdot\text{cm}$)	18,2
Total Organic Carbon (ppb)	10
Sodium (ppb)	1
Chloride (ppb)	1
Total Silica (ppb)	3
Bacterial Content (ufc/ml)	1
Endotoxins (IU/ml)	< 0,03

Table 2

Element	Recently Obtained Water (ppb)	15 days old in Pyrex (ppb)
Zn	14	46
Pb	9	30
Cu	5	12
Fe	9	45
Al	10	102

The Wasserlab Ultramatic equipment produces, and instantly dispenses at the user's demand, Type I Ultrapure Reagent Grade water which exceeds the ASTM quality standards, adapting to the various purity requirements of each user according to the analysis techniques applied.

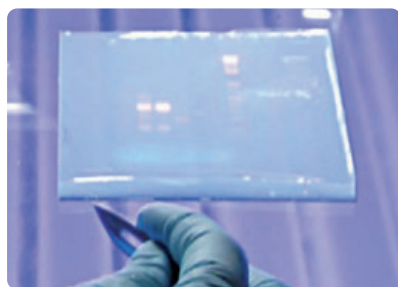

Basis

Ultramatic dispenses 1.1 litres/minute of Ultrapure water Type I Reagent Grade water of 18.2 MΩ.cm at 25 °C, COT < 10 ppb and bacterial count ≤1 ufc/ml, from prepurified water:

- | Type II Water (Ecomatic/Autwomatic)
- | Osmotised Water
- | Deionised Water
- | Distilled Water

The prepurified water passes through:

- | A **GR** purification module that reduces contaminating ions to traces level.
- | A photo oxidation module that reduces organic contamination to traces level.
- | An ultra filtration module that eliminates pyrogens and nucleases ("Ultramatic GR UF").
- | The water is dispensed through a 0.2 microns amicrobic filter.

Photo oxidation

Ultramatic includes a photo oxidation module as a serial feature, and its lamps emits:

- | UV radiation at 254 nm with germicide activity (irreversibly alters bacterial DNA).
- | Radiation at 185 nm with the capacity to generate free hydroxyl radicals that oxidise the organic compounds dissolved in the water into ions, carbonate and bicarbonate which will be retained by the third **GR** purification module.

Ultra-filtering: Elimination of pyrogens and nucleases

For the more critical applications in molecular biology (PCR, DNA sequencing, cellular cultures, electrophoresis....) a hydrophylic membrane of encapsulated hollow fibre, with a large filtering surface, eliminates the pyrogens and nucleases in the water.

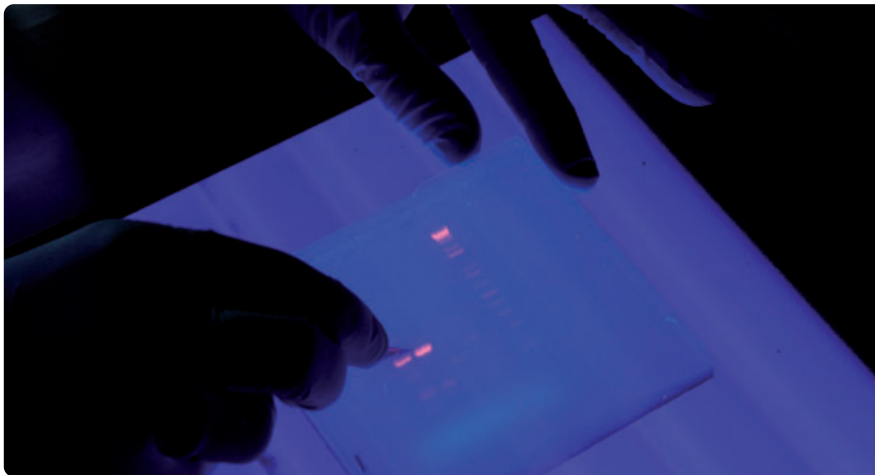

Applications

Ultramatic is the ideal equipment for the most critical laboratory techniques:

- | ICP-MS/ ICP/ AA
- | HPLC
- | Ionic chromatography
- | GC-MS
- | Molecular Biology
- | PCR
- | Cellular Cultures
- | DNA Sequencing

Measurement of resistivity

Ultramatic provides a continuous measurement of the water's resistivity ($\pm 0,1 \text{ M}\Omega\cdot\text{cm}$) with temperature compensation ($\pm 0,1 \text{ }^\circ\text{C}$).

As a safety mechanism for users, the equipment software includes a prefixed set point value (10 $\text{M}\Omega\cdot\text{cm}$), and if under this value, the equipment does not dispense water.

Automatic recirculation

Ultramatic automatically recirculates the water contained in its circuit, ensuring the maximum quality of the water dispensed.

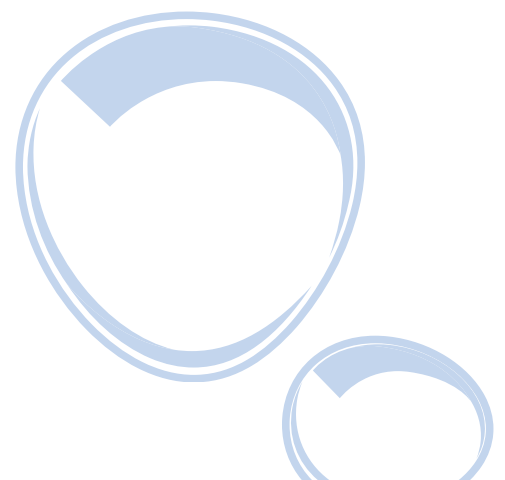



Numerous clients already trust the Wasserlab products

- Universities all over Spain
- Leading research centres throughout the country
- Hospitals of national reference
- Market leading manufacturers of hospital equipment

www.wasserlab.com

Water purifier	ECOMATIC	AUTWOMATIC		ULTRAMATIC	
Model	Standard	Standard	UV	GR	GRUF
Final Water Quality	Type II	Type II	Type II	Type I	Type I
Flow Rate LPH*	3/5/10	3/5/10	3/5/10	1,1 l/min	1,1 l/min
Max. Flow rate LPD	60/100/200	60/100/200	60/100/200		
Pretreatment Cartridges	✓	✓	✓		
Deionization Cartridges	✓	✓	✓		
Ultrapure GR Cartridges				✓	✓
Ultrafiltration Cartridge					✓
RO Pressurized Tank	10/30/50/100	10/30/50/100	10/30/50/100		
Pressure Gauge	1	1	1		
Interactive Display	numeric	alphanumeric	alphanumeric	alphanumeric	alphanumeric
Visual and audible warning messages	✓	✓	✓	✓	✓
Continuous Monitorization					
Feed Water Conductivity		± 1 µS/cm	± 1 µS/cm		
Osmotized water Conductivity		± 1 µS/cm	± 1 µS/cm		
Ionic Rejection %		± 0,1%	± 0,1%		
Type II Water Conductivity	± 0,1 µS/cm	± 0,1 µS/cm	± 0,1 µS/cm		
Type I Water Resistivity				± 0,1 MΩ.cm	± 0,1 MΩ.cm
Work Time counter	✓	✓	✓		
Water Temperature		± 0,1°C	± 0,1°C	± 0,1°C	± 0,1°C
Temperature compensation	✓	✓	✓	✓	✓
Messages					
Out of range parameters	✓	✓	✓	✓	✓
RO Exchange		✓	✓		
DI cartridge exchange	✓	✓	✓		
Pretreatment cartridge exchange	✓	✓	✓		
Ultrapure GR cartridge exchange				✓	✓
Feed water supply failure	✓				
Automation					
Full tank stop	✓	✓	✓		
Automatic Start/Stop	✓	✓	✓		
Automatic recirculation				✓	✓
Automatic Stop/water supply failure	✓	✓	✓		
Other components					
Foto oxidation lamp			✓	✓	✓
Final filter 0,2 micron		opc	✓	✓	✓
DI increasable	opc	opc	opc		
Ultrafiltration cartridge					✓
Dimensions (Width/Height/Depth) [cm]	45x25x48	52x25x48		52x25x48	
Weight [kg]	12	15		12	
Power supply	220 V / 50 Hz	220 V / 50 Hz		220 V / 50 Hz	
Feed Water Requirements					
Min. Inlet Pressure	2 bar	2 bar		1 bar	
Max. Inlet Pressure	6 bar	6 bar		4 bar	
Max. Water Temperature	30° C	30° C		30° C	
Max. Hardness	360 ppm (CaCO ₃)	360 ppm (CaCO ₃)			
SDI (Silt Density Index)	<5	<5			
Max. Feed Water conductivity	1000 µS/cm	2000 µS/cm	2000 µS/cm	20 µS/cm	20 µS/cm
Free Chlorine	< 2 ppm	< 2 ppm			
Turbidity	< 1 NTU	< 1 NTU			

* Other Flow rates and storage tanks are available, according to customer needs.

The advantages of our systems

Constant quality
Reliability
Simple and efficient
management

DISTRIBUTED BY:

www.wasserlab.com

Pol. Ind. Comarca II • Calle A, nº 26
31191 Barbatain (Navarra) Spain • T +34 948 186 141